



# CO<sub>2</sub> Room Sensor in a BAPI-Stat Quantum Enclosure

Installation and Operating Instructions

40567\_ins\_BSQ\_CO2

rev. 07/12/22

## Identification and Overview

The BAPI-Stat “Quantum” CO<sub>2</sub> Sensor is an accurate and reliable way of incorporating demand controlled ventilation into a building’s HVAC strategy. It measures the CO<sub>2</sub> in a range of 0 to 2,000 ppm with a field selectable output of 0 to 5 or 0 to 10 VDC.

BAPI’s Dual Channel (DCD) “24/7” unit has been optimized for continuously occupied areas and features a three-point calibration process for enhanced stability, accuracy and reliability.

Air pressure changes from altitude or weather patterns can affect the output of CO<sub>2</sub> sensors, even putting them outside of their specified accuracy. The BAPI unit has a built-in barometric sensor that continuously compensates the output for accurate readings despite the weather or altitude of the installation.

The CO<sub>2</sub> level is indicated as “Good, Fair or Poor” by three discrete green, yellow and red LED’s on the front of the unit. If it reaches the top of the PPM range, the red LED will begin to flash.

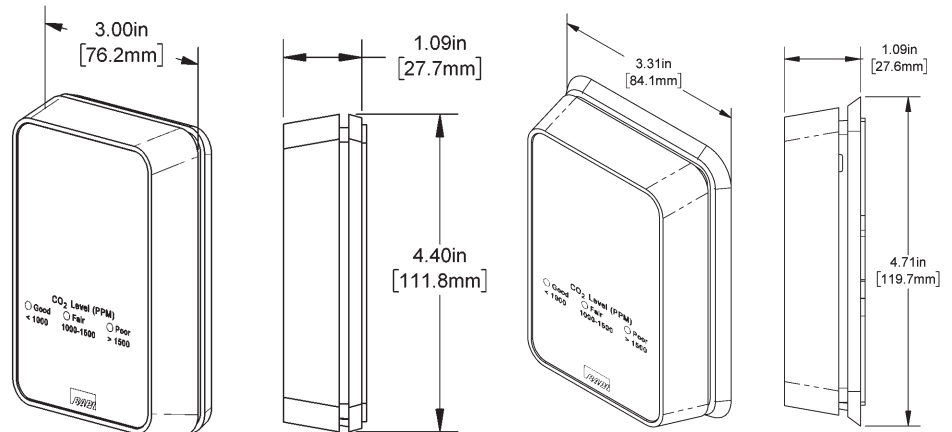

**Fig. 1:** BAPI-Stat “Quantum” CO<sub>2</sub> Sensor (standard mounting base at left and 60mm mounting base for European wall boxes with 60mm mounting centers at right)

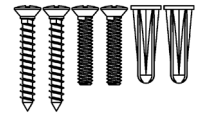

**Included Screw Pack**

## Specifications

### Power:

12 to 24 VDC, 240 mA  
18 to 24 VAC, 12 VA Peak

### Sensing Elements:

Dual Channel Non-Dispersive Infrared (NDIR)

### Field Selectable Voltage Output:

0 to 5 or 0 to 10 VDC >4KΩ impedance

**Termination:** 3 Terminals, 16 to 22 AWG

### Operating Environment:

32 to 122°F (0 to 50°C)  
0 to 95%RH non-condensing

**Enclosure Material:** ABS Plastic, Material Rated UL94V-O

### CO<sub>2</sub> Detection Range:

0 to 2,000 ppm

**Start-Up Time:** <2 Minutes

### Response Time:

<2 Minutes for 90% step change typical (after start-up)

**Mounting:** Standard 2”x4” junction box, European junction box or drywall mount (screws provided)

### CO<sub>2</sub> Accuracy:

400 to 1,000 ppm: ±75 ppm  
>1,000 ppm: ±10% of reading

### CO<sub>2</sub> Drift Stability:

<5% of full scale over life of product.

### LED CO<sub>2</sub> Level Indicator

(for 0 to 2,000 PPM units only):

Good, Green < 1,000 PPM  
Fair, Yellow = 1,000 to 1,500 PPM  
Poor, Red > 1,500 PPM

**Certifications:** RoHS

**Warranty Period:** 5 Years

Specifications subject to change without notice.

### Mounting

Mounting hardware is provided for both junction box and drywall installation (junction box installation shown).

Note: Screw the 1/16" Allen lock-down screw into the base to open the case. Back out the lock-down screw to secure the cover.

#### Junction Box

1. Pull the wire through the wall and out of the junction box, leaving about six inches free.
2. Pull the wire through the hole in the base plate.
3. Secure the plate to the box using the #6-32 x 5/8 inch mounting screws provided.
4. Terminate the unit according to the guidelines in the Termination section. (page 3)
5. Mold the foam on the unit's base to the wire bundle to prevent drafts. (see note below)
6. Attach Cover by latching it to the top of the base, rotating the cover down and snapping it into place.
7. Secure the cover by backing out the lock-down screw using a 1/16" Allen wrench until it is flush with the bottom of the cover.

#### Drywall Mounting

1. Place the base plate against the wall where you want to mount the sensor. Mark out the two mounting holes and the area where the wires will come through the wall.
2. Drill two 3/16" holes in the center of each marked mounting hole, DO NOT punch the holes or the drywall anchors will not hold. Insert a drywall anchor into each hole.
3. Drill one 1/2" hole in the middle of the marked wiring area.
4. Pull the wire through the wall and out of the 1/2" hole, leaving about six inches free. Pull the wire through the hole in the base plate.
5. Secure the base to the drywall anchors using the #6 x 1 inch mounting screws provided.
6. Terminate the unit according to the guidelines in the Termination section. (page 3)
7. Mold the foam on the unit's base to the wire bundle to prevent drafts. (see note below)
8. Attach cover by latching it to the top of the base, rotating the cover down and snapping it into place.
9. Secure the cover by backing out the lock-down screw using a 1/16" Allen wrench until it is flush with the bottom of the cover.

NOTE: In any wall-mount application, the wall temperature and the temperature of the air within the wall cavity can cause erroneous readings. The mixing of room air and air from within the wall cavity can lead to condensation, erroneous readings and sensor failure. To prevent these conditions, BAPI recommends sealing the conduit leading to the junction box, filling the junction box with fiberglass insulation or sealing the wall cavity.

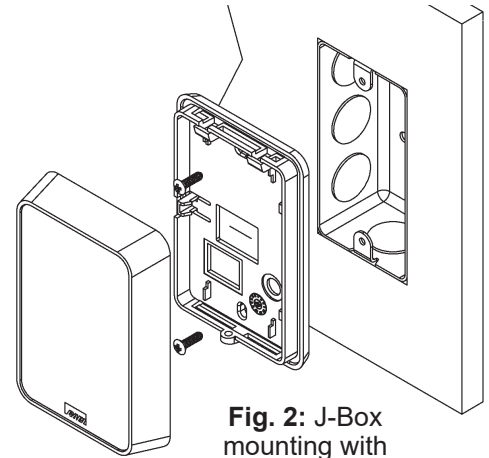

Fig. 2: J-Box mounting with standard base

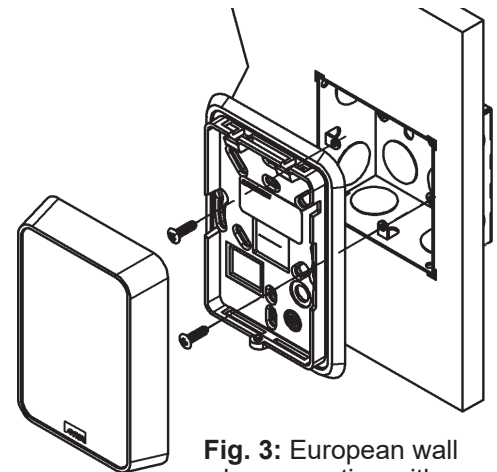

Fig. 3: European wall box mounting with 60mm base

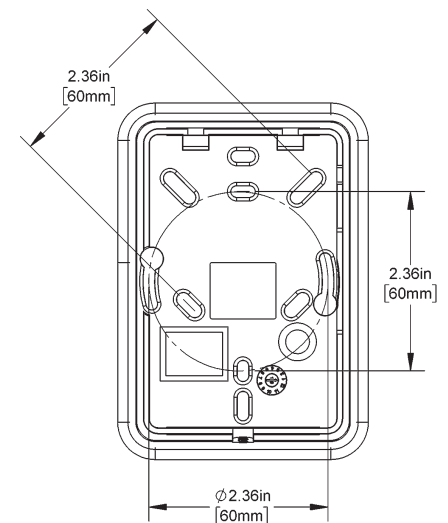

Fig. 4: 60mm mounting base dimensions

Specifications subject to change without notice.



# CO<sub>2</sub> Room Sensor in a BAPI-Stat Quantum Enclosure

Installation and Operating Instructions

40567\_ins\_BSQ\_CO2

rev. 07/12/22

## Termination

BAPI recommends using twisted pair of at least 22AWG and sealant filled connectors for all wire connections. Larger gauge wire may be required for long runs. All wiring must comply with the National Electric Code (NEC) and local codes. Do NOT run this device's wiring in the same conduit as AC power wiring of NEC class 1, NEC class 2, NEC class 3 or with wiring used to supply highly inductive loads such as motors, contactors and relays. BAPI's tests show that fluctuating and inaccurate signal levels are possible when AC power wiring is present in the same conduit as the signal lines. If you are experiencing any of these difficulties, please contact your BAPI representative.



BAPI recommends wiring the product with power disconnected. Proper supply voltage, polarity, and wiring connections are important to a successful installation. Not observing these recommendations may damage the product and will void the warranty.

Note: Unit is not ready for operation until the ten-minute start-up time has elapsed.

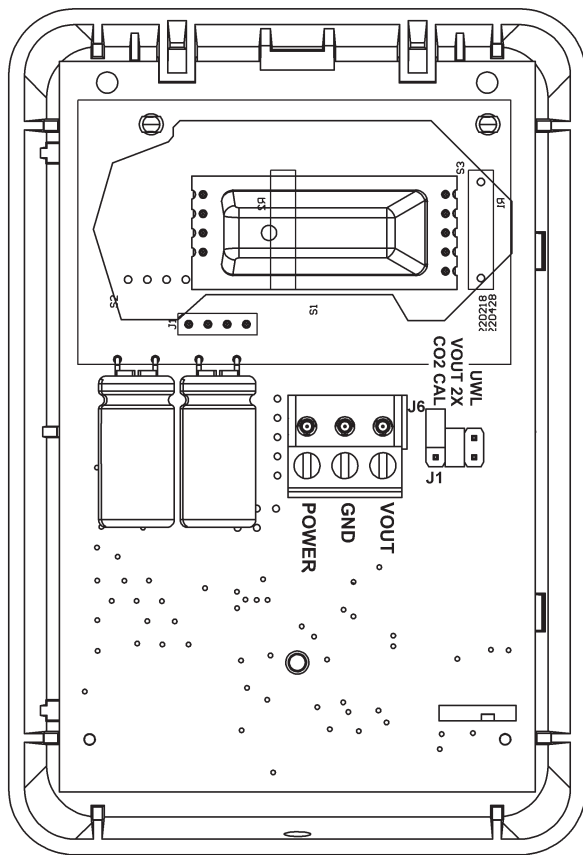

Fig. 5: Circuit Board

### Terminal Function

**VOUT**..... Voltage Output, CO<sub>2</sub> Signal  
0 to 5 or 0 to 10 VDC, Referenced to GND

**Note:** The CO<sub>2</sub> Output may be field configured for 0 to 5 or 0 to 10 VDC outputs at any time. Set the Jumper on J1 as shown in Fig. 6 & 7 below.

**GND**..... To controller Ground [GND or Common]

**POWER**..... 12 to 24 VDC, 240mA  
18 to 24 VAC, 12 VA Peak

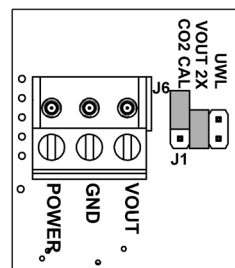

Fig. 6: J1 Set for 0 to 10 VDC Output

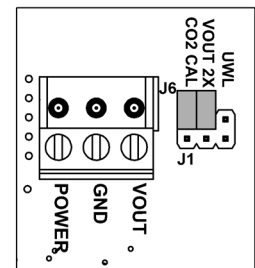

Fig. 7: J1 Set for 0 to 5 VDC Output

## POWERING WITH A BAPI VC350A VOLTAGE CONVERTER

The CO<sub>2</sub> unit requires 240mA of current to operate correctly. If this is more current than can be provided by the controller power output, then the unit can be powered by a BAPI VC350A or VC350A-EZ Voltage Converter.

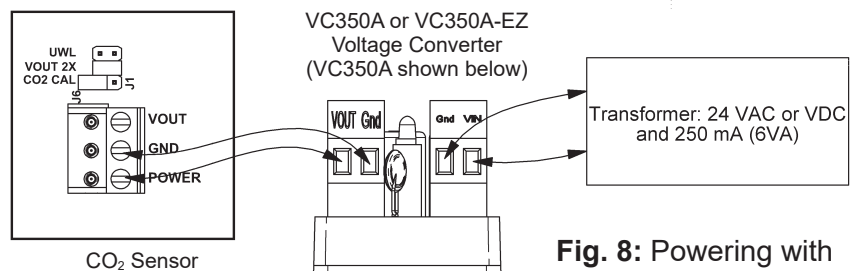

Fig. 8: Powering with a BAPI VC350A

Specifications subject to change without notice.



# CO<sub>2</sub> Room Sensor in a BAPI-Stat Quantum Enclosure

Installation and Operating Instructions

40567\_ins\_BSQ\_CO2

rev. 07/12/22

## Diagnostics

### Possible Problems:

General troubleshooting

### Possible Solutions:

Determine that the input is set up correctly in the controller's and building automation software.

Check wiring at the sensor and controller for proper connections.

Check for corrosion at either the controller or the sensor. Clean off the corrosion, re-strip the interconnecting wire and reapply the connection. In extreme cases, replace the controller, interconnecting wire and/or sensor.

Check the wiring between the sensor and controller. Label the terminals at the sensor end and the controller end. Disconnect the interconnecting wires from the controller and the sensor. With the wires disconnected, measure the resistance from wire-to-wire with a multimeter. The meter should read greater than 10 Meg-ohms, open or OL depending on the meter. Short the interconnecting wires together at one end. Go to the other end and measure the resistance from wire-to-wire with a multimeter. The meter should read less than 10 ohms (22 gauge or larger, 250 feet or less). If either test fails, replace the wire.

Check power supply/controller voltage supply

Disconnect sensor and check power wires for proper voltage (see specifications on page 1)

Incorrect CO<sub>2</sub>

Wait 15 minutes after a power interruption.

Check all BAS controller software parameters.

Determine if the sensor is exposed to an external environment different from the room environment (conduit draft).

If the sensor is reading consistently high, make sure that the power supply to the unit can provide 240 mA. A low power situation will cause high CO<sub>2</sub> readings.

Note: If the CO<sub>2</sub> sensor has consistently given high PPM readings for over 5 days, it will take up to 14 days for the readings to return to normal.

Specifications subject to change without notice.